



Head Office.

15 Nablus St, from Shehab St,
Floor 4, App 10, Mohandessin, A.R.E
T. +202 33024067 F. +202 33423085

Factory.

2nd Industrial Zone Plot BG/9,
Sadat City, Al Monofia Governorate A.R.E
T. +2048 2656307 M. +201000443663



info@migagreen.com
www.migagreen.com
migagreenplast



miga
green
plastic
industries

www.migagreen.com

	Introduction (English Version)	1
	Introduction (Arabic Version)	4
	Single/Double Union ball valve Diagram	7
	Metric Series Plain & BS Threaded (Single Union)	8
	Metric Series Plain & BS Threaded (Double Union)	9
	Metric Series Plain & BS Threaded (Full Injected)	10
	BS Plain /Threaded	11
	BS Plain /Threaded	12
	BS & Metric Series	13
	Metric Series solvent	15
	Metric Series solvent	16
	Metric Series solvent	17
	Metric Series solvent	18
	Metric Series solvent	19
	Metric Series solvent	20
	BS Threaded / Metric Solvent	21
	BS Threaded / Metric Solvent	22
	BS Plain	23
	BS / Metric Solvent	24
	BS Plain/Threaded	25
	BS Plain/Threaded	26
	Solutions	27
	Packing Sizes	29
	Certificates	30



? who are we

Miga Green was founded in 2017, although it was recently founded, it has a noticeable impact on the local market as if it were founded ten years ago.. In fact, these years considered to be the outcome of the company's administrative experience which has a thorough look over marketing and its needs and how to fulfill them in a noticeable way. These needs were fulfilled using a scientific well -studied attitude and within a frame of a competitive style.

That enables the company to last on a supportive basis to make a well reputable name not only in the local marketing but in the international marketing also.

Miga Green

introduces a set of valves, pieces different in shapes and sizes. Moreover, it introduces a variety of practical solutions to different sectors, especially those using Miga Green; (irrigation systems, reprocessing of water, swimming pools, and different kinds of foods, gas and petroleum).



Distinction and high quality, both go an eye to an eye, are considered two essential pillars enhancing success established by Miga Green since it has created a distinctive different product, compared to the others. Though the Egyptian market has some reputable companies, Miga Green starts to flourish which prompts many other companies of competitive companies to have an overall look, perceiving the success criteria of those products, developed with steady strides heading to the peak of success. It has been surely considered a miraculous step in a short time in the field of U- PVC.

Our products

Have greatly satisfied the customers' needs since it was founded , it has fully satisfied their needs, that leads to make its amongst these pioneers of the U- PVC products throughout introducing a framework of service after selling its products and the periodical evaluation and reassuring its safety through continuous visits to achieve technical support.

Miga Green's has got a considerable experienced staff members in all sectors: administrative and as marketing plans and policies are being set to achieve fruitful results as well as specialists to make good use go their suggestions in all the fields, especially, irrigation which is considered as the biggest sector to Miga Green's company.

As a result of the interaction of all the previous factors and the considerable efforts of its workers, it has passed several tests and finally got many certificates which prove its quality of its products.

The advantages of to Miga Green's products

- The life time of their products may be over 50 years
- It offers spare parts in case of damage of misusing

Technical Usages:

unplasticised polvinyl chloride is considered to be, a non sticky substance, is the most widely used substance in the manufacture of water pipes and those pieces in the construction fields, which is characterized with its strong resistance against the chemical substances. Thus, it is considered to be the most ideal even suitable for drinking purposes which is truly valid since it doesn't react with any other liquids passing through them.

Accordingly, it is also used in some nutritional liquids; neither affecting their odour, taste nor colour. Moreover , it doesn't react with the acidic or the alkaline solutions.



INSTRUCTIONS

1. Cleaning the wanted parts using a piece of dry cloth , to wipe away any oil traces.
2. Adding the required quantities from the sticky substance to the edges of the parts aimed to be stuck , using a brush specified to that matter so as we could cover up the required part needed to be stuck.
3. Attaching different parts. (positive and negative)
4. Cleaning up the extra material of the sticky substance.
5. Carrying out tests to measure water pressure and its flow after 24 hours and its effect on the sticky substance.
6. Stuck parts † be subjected to any mechanical pressures except after the due time.



PRESSURE-TEMPERATURE RELATIONSHIP ACCORDING TO DIN 3441 BLATT 1 AND EN 145£/3/5

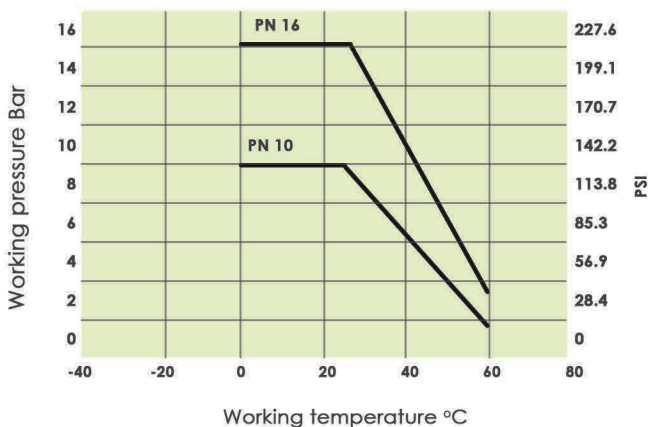

PHYSICAL PROPERTIES OF PVC-U

Characteristics	Standard	Units	PVC
Density	ISO 1183	kg/dm ³	1,40
Elongation	ISO R527	%	154
Modulus of elasticity	ISO R527	MPa	2.600
Resistance to traction	ISO R527	MPa	40
Tensile strength	ISO R527	MPa	44
Vicat softening point with 5Kgs	ISO 306	°C	> 76
Thermal conductivity 23°C	ASTM C177	$\frac{w}{mk}$	0,13±0,19
Coefficient of linear expansion	ASTM D696 UNI 6061	$\frac{mm}{mm°C}$	5÷8x10 ⁻⁵
Water absorption	UNI 7449-75	mg/cm ²	< 0,1
Meets fire regulations	UL94		V-O
Ash content	UNI 7449-75	%	< 3
Colour			9735



من نحن؟

ميجا جرين

تأسست في عام ٢٠١٧ ، وعلى الرغم من وجودها الحديث فقد أثرت في السوق المحلي بشكل أوسع للجميع أن عمرها يتعدى عشرات السنين ، و في حقيقة الأمر تلك السنوات ماهي إلا خبرات مجلس إدارة الشركة ؛ الذي ظل يحرس السوق ومتطلباته وكيفية توفير احتياجاته بشكل علمي محروس وبأسلوب تنافسي يُمكن الشركة من الوقوف الراسخ ليصبح اسم ميجا جرين لامعا في السوق المحلي ومنه إلى الأسواق العالمية .



التميز و الجودة

المتلازمان لمنتجات ميجا جرين ماهما إلا أعمدة النجاح التي أسستها ميجا جرين وعملت على خلق منتج يختلف عن غيره ، فإن كان السوق المصري يحتوى على عدة أسماء في نفس المجال ، إلا أن اسم ميجا جرين بدأ مزدهراً دفع الكثير من الشركات المنافسة لإعادة النظر والمقارنة والوقوف على معايير نجاح تلك المنتجات التي صعدت بخطوات ثابتة نحو القمة في زمن قياسي اعتبره البعض بمثابة معجزة في مجال تصنيع الـ U-PVC

توفر ميجا جرين العديد من المحابس والوصلات والقطع

بمختلف المقاسات وبعده أشكال ، كما توفر حلول عملية في كافة القطاعات المستخدمة لمنتجاتها ؛ ومنها (أنظمة الري ، محطات معالجة المياه بكافة أشكالها ، البنية التحتية ، حمامات السباحة ، المواد الغذائية ، الغاز والبتروول) .

تضم ميجا جرين فريق عمل ذات خبرات كبيرة

في جميع الأقسام (الإدارية ، التشغيلية ، والبيعية ، والدعم الفني) حيث يتم رسم السياسات التسويقية والخطط البيعية التي من شأنها تحقق الأهداف المرجوة ، كما تحرص دائما على الاستعانة بالإستشاريين للاستفادة من خبراتهم ومقترحاتهم في جميع المجالات ، وبالأخص مجال الري الذي يعتبر القطاع الأكبر لمنتجات ميجا جرين .

حازت منتجات ميجا جرين على رضا الكثير من العملاء

ومنذ نشأتها قد حرصت ميجا جرين على ثبات مبدأ رضا العميل جعل منها أحد أهم الشركات المصنعة لمنتجات الـ U-PVC وذلك من خلال تقديم خدمة ما بعد البيع والتقييم الدوري لمنتجاتها والتأكد من سلامتها ؛ من خلال زيارات ميدانية لتقديم الدعم الفني اللازم .

نتيجة تكامل العوامل السابقة وتضافر جهود جميع العاملين بالشركة فقد اجتازت ميجا جرين عدة اختبارات وحصلت على شهادات تؤكد مدى جودة منتجاتها .

- نظام ادارة الجودة
- نظام إدارة الصحة والسلامة
- شهادة اعتماد الهيئة القومية لمياة الشرب والصرف الصحي
- ISO 9001:2015
- ISO 45001:2018
- DIN -8063EN1452

من أحد أهم مميزات منتجات ميجا جرين : طول العمر الافتراضى لها يصل الى خمسون عام وفترة ضمان قد تصل الى **عشر سنوات** , بالإضافة إلى توفير قطع الغيار اللازمة (الداخلية / الخارجية) حالة حدوث تلف ناتج عن سوء الاستخدام ; مما يضمن الحفاظ على كفاءة الأداء طوال فترة تشغيلها.

المواصفات الفنية

تعتبر مادة البولس فينيل كلوريد غير اللدن من المواد الأكثر استخداما فى تصنيع المواسير والقطع التى تدخل فى الأعمال الإنشائية , و تتميز بمقاومتها الشديدة للمواد الكيماوية ; لذا تعتبر المادة الأمثل لاستخدامها فى تشيكلات المياه الصالحة للشرب , ونظراً لعدم تفاعلها مع أي سوائل تمر من خلالها فقد تم استخدامها أيضا للسوائل الغذائية فهى لا تؤثر على اللون أو الطعم أو الرائحة ولا تتفاعل مع معظم المحاليل الحمضية والقلوية.

إرشادات

توصى ميجا جرين استخدام مادة لاصقة معتمدة بحيث تتم عملية اللصق بشكل صحيح و آمن دون حدوث أي أثر سلبي من شأنه التأثير على كفاءة المنتج أثناء اختباره أو تشغيله , وتنقسم المادة اللاصقة إلى نوعين :

المادة اللاصقة السائلة

يُنصح باستخدامها للصلق القطع والوصلات ذات الأقطار الضيقة على ألا يتعدى قطر القطعة الواحدة الـ ٣ مليمترات .

المادة اللاصقة السميكة

يُنصح باستخدامها للصلق القطع والوصلات ذات الأقطار العريضة على ألا يتعدى قطر القطعة الواحدة الـ ٦ مليمترات .

تعليمات التركيب

- ١ تنظيف القطع و الأجزاء المراد استخدامها باستخدام قطعة قماش جافة لمسح كافة آثار السخيم , أو الزيت , أو الغبار.
- ٢ إضافة الكمية المطلوبة من المادة اللاصقة على حواف الأجزاء المراد لصقها باستخدام فُرستاة مُخصصة لهذا الأمر حتى يتم تغطية المساحة المراد لصقها بشكل كامل.
- ٣ توصيل الأجزاء المُختلفة (الذكر , و الأنثى) بقرنائهم فى مدى زمني أقل من دقيقة
- ٤ مسح الفائض من المادة اللاصقة فوراً.
- ٥ عمل اختبارات لقياس ضغط الماء و مدى التدفُّق بعد مرور ٧٤ ساعة على اللصق.
- ٦ عدم تعريض أيّة من الأجزاء المُغراة إلى ضغوطات ميكانيكية إلا بعد مُضي الفترة المُوجه بتجاوزها .



تنفرد ميجا جرين بتصنيع محابس حامل الجوان السن:

وتستخدم فى حالة تركيب المحابس على المياة المفلترة بقدرة او فى حالة الوضع المفتوح دائماً او المغلق دائماً .

ايضا تصنيع محابس حامل الجوان الحر:

وتستخدم فى حالة تركيب المحابس على محطات الفلاتر والتشبيكات اليدوية لزيادة العمر الافتراضى للتشغيل





U^{PVC}
valves



SINGLE UNION Ball valve with BS male solvent / Female Threaded

(components details)

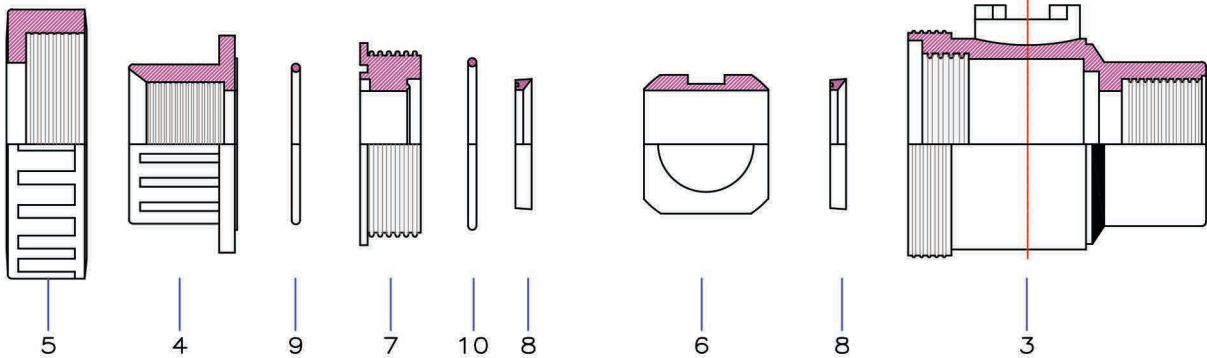
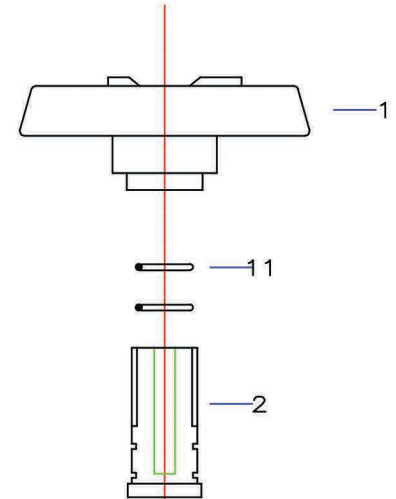
Pos.	Components	N°	Material
1	Handle	1	ABS
2	Stem	1	PVC
3	Body	1	PVC
4	Union end	1	PVC
5	Union Nut	1	PVC
6	Ball	1	PVC
7	Support	1	PVC
8	Ball Seat	2	PTFE
9	Union o-ring	2	EPDM
10	o-ring sealing bush	1	EPDM
11	o-ring stem	2	EPDM



DOUBLE UNION Ball valve with BS male solvent / Female Threaded

(components details)

Pos.	Components	N°	Material
1	Handle	1	ABS
2	Stem	1	PVC
3	Body	1	PVC
4	Union end	2	PVC
5	Union Nut	2	PVC
6	Ball	1	PVC
7	Support	1	PVC
8	Ball Seat	1	PTFE
9	Union o-ring	2	EPDM
10	o-ring sealing bush	1	EPDM
11	o-ring stem	2	EPDM

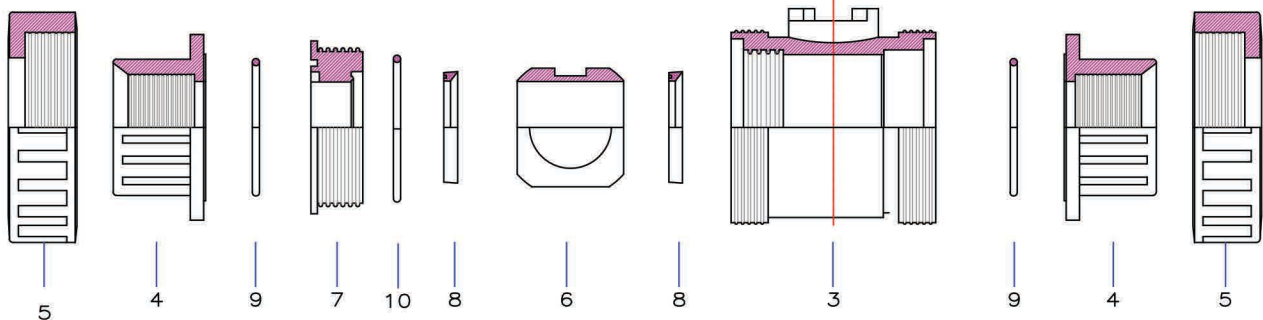
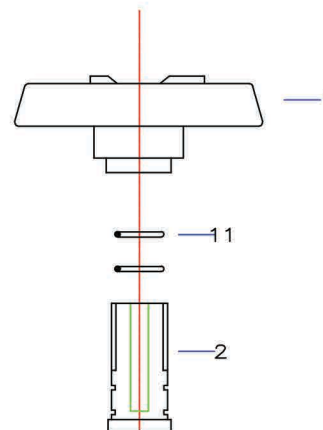

U-PVC Ball Valves



محابس الكورة

Single union ball valve with female plain ends for solvents welding

MGSBVT7

محبس لاکور لصق

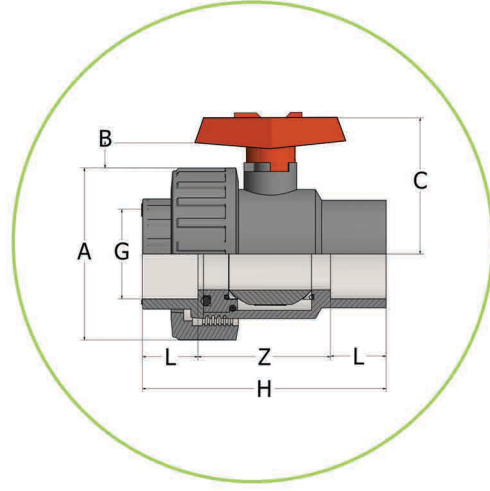

Code	D	DN	L	Z	H	A	B	C	E	F	PN	Quantity	GR
MGSBV063T6	63	50	38	92	186	124	20	105	80	40	16	20	1097

Single union ball valve with female threaded ends

MGSBVT6

محبس لاکور سن (قلاووظ)

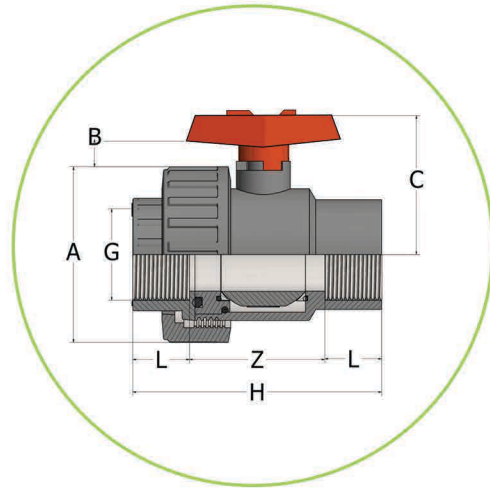

Code	G	DN	L	Z	H	A	B	C	E	F	PN	Quantity	GR
MGSBV063T6	2	50	38	92	186	124	20	105	80	40	16	20	1145



Double union ball valve with plain ends for solvent welding

محبس لاكورين لصق

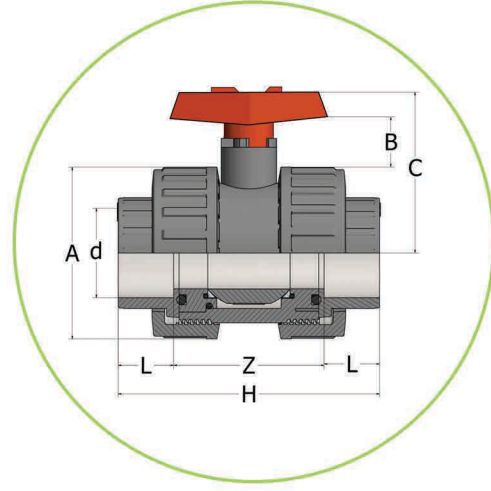

Code	D	DN	L	Z	H	A	B	C	E	F	PN	Quantity	GR
MGDBVT063T7	63	50	38	94	170	116	20	101	80	40	16	-	-

Double union ball valve with female threaded ends.

MGDBVT6

محبس لاكورين سن (قلاووظ)

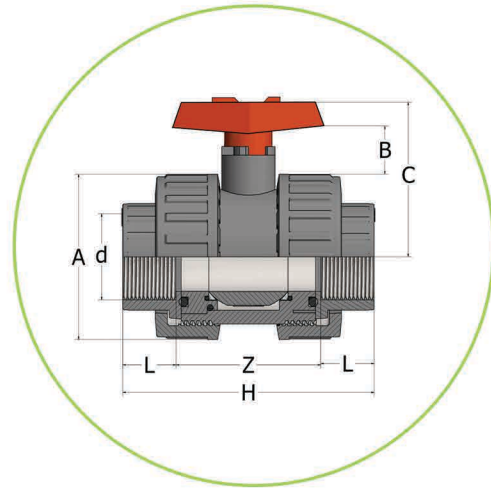

Code	D	DN	L	Z	H	A	B	C	E	F	PN	Quantity	GR
MGDBV063T6	2"	50	38	94	170	116	20	101	80	40	16	-	-

U-PVC Ball Valves



محابس الكورة

Ball valve with plain ends
for solvent welding

MGBVT7

محبس كورة لصق

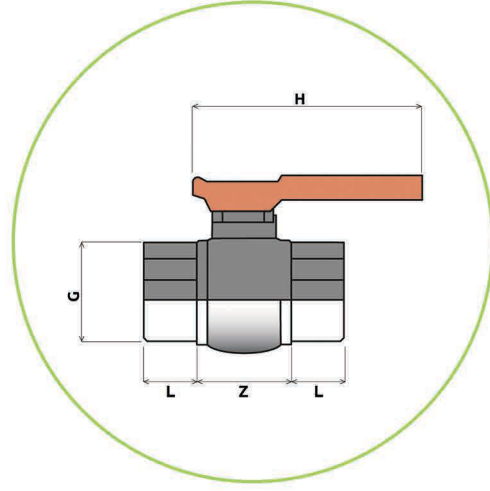

Code	D	L	G	Z	H	PN	Quantity	GR
MGBV063T6	63	35	70	70	165	16	30	570

Ball valve with female
threaded ends.

MGBVT6

محبس كورة سن (قلاووظ)

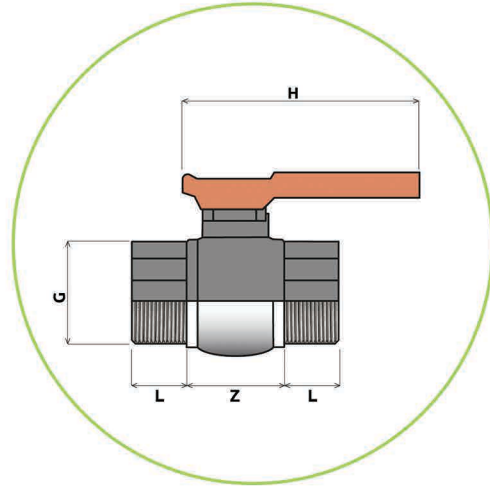

Code	D	L	G	Z	H	PN	Quantity	GR
MGBV063T6	2"	35	70	70	165	16	30	585



Single union ball valve with BS male solvent / Female Threaded

MGSBVT5

محبس لاکور لصق في سن

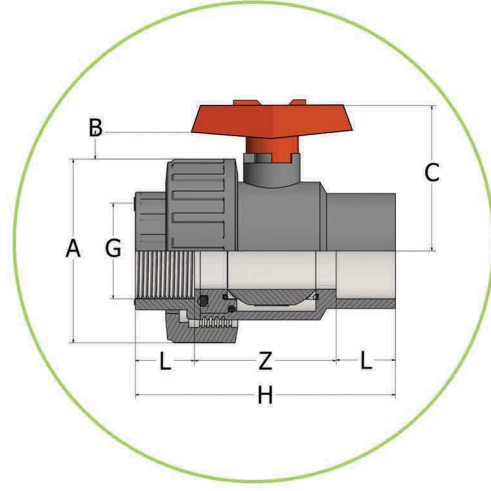

Code	D	DN	L	Z	H	A	B	C	E	F	PN	Quantity	GR
MGSBV063T5	2"	50	38	92	186	124	20	105	80	40	16	20	1117

Double union ball valve with BS female solvent / Threaded

MGDBVT5

محبس لاکورين لصق في سن

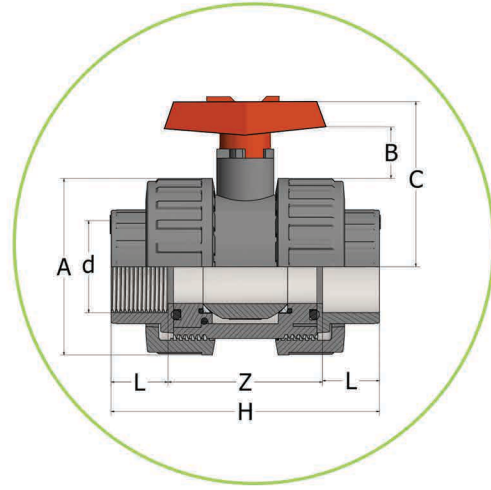

Code	D	DN	L	Z	H	A	B	C	E	F	PN	Quantity	GR
MGDBV063T5	2"	50	38	94	170	124	20	105	80	40	16		

U-PVC Ball Valves



محابس الكورة

Ball valve with BS female solvent welding /threaded

MGBVT5

محبس كورة لصق في سن

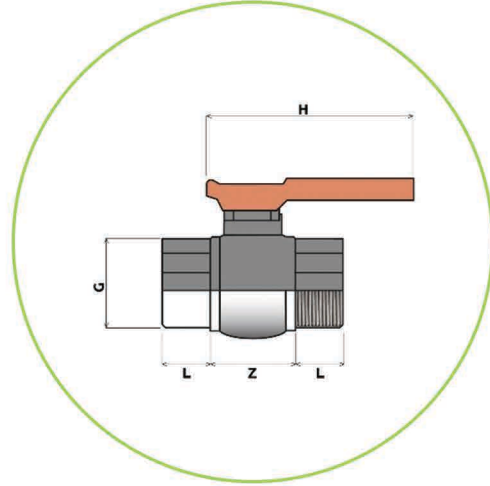

Code	D	L	G	Z	H	PN	Quantity	GR
MGBV063T5	2"	35	70	70	165	16	30	585

FLAP-VALVE

MGFVL7

محبس عدم رجوع بوابة

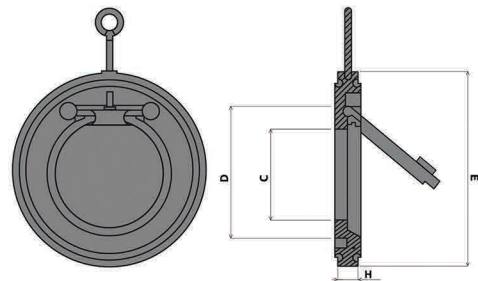

Code	D	C	H	E	Quantity	GR
	mm	mm	mm	mm		
MGFV225L7	8"/225	138	34	245	15	1430



Butterfly valve Hand operated

MGBFV7

محبس الفراشة

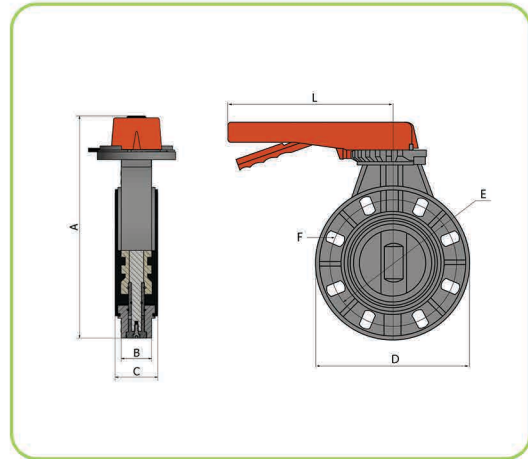

Codes	D	PN	A	B	C	D	E	F	L	Cartoon	GR
MGBFV090R7	3"/90	10	250	40	54	194	152.5	19x26.5	239	12	1710
MGBFV110Q7	4"/110	10	284	43	57.3	227	185	19x24.5	239	10	2250
MGBFV160N7	6"/160	10	349	48	67.5	284	239	22x25	274	6	4715



Strong
product
high-Quality



Code	d	L	Z	E	PN	Quantity	Gr
------	---	---	---	---	----	----------	----

Commercial Code

Diameter

Dimension

Nominal Pressure

Units Per Pack

Weight Per Unit



Strong product
 high-Quality



Tee 90°

MGTE7

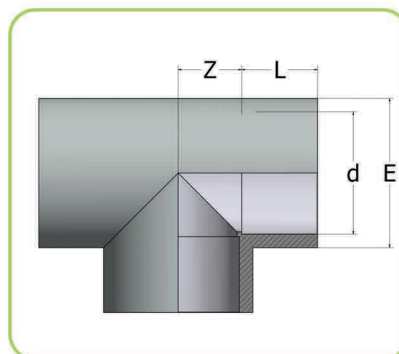
مستترك 90°



Codes	D	L	Z	E	PN	Quantity	GR
MGTE032W7	32	22	17	42	16	80	209
MGTE050U7	50	31	26	61	16	65	210
MGTE063T7	63	38	33	75	16	57	233
MGTE090R7	90	51	47	105	16	18	665
MGTE110Q7	110	61	57	128	16	10	1390
MGTE125P7	125	69	64	145	16	8	1850
MGTE160N7	160	86	81	184	10	3	3055

Elbow 90°

MGEL7

كوع 90°

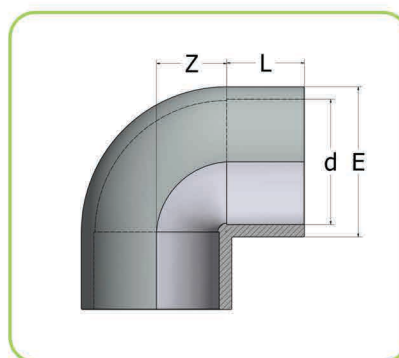

Codes	D	L	Z	E	PN	Quantity	GR
MGEL032W7	32	22	17	41	16	200	59
MGEL050U7	50	31	28	60	16	132	165
MGEL063T7	63	38	34	75	16	65	196
MGEL075S7	75	44	40	89	16	42	270
MGRLO90R7	90	51	48	105	16	25	581
MGEL110Q7	110	61	58	128	16	15	1260
MGEL125P7	125	69	66	145	16	8	1175
MGEL160N7	160	86	81	184	10	4	2330



Socket

MGSO7

جلبٲة

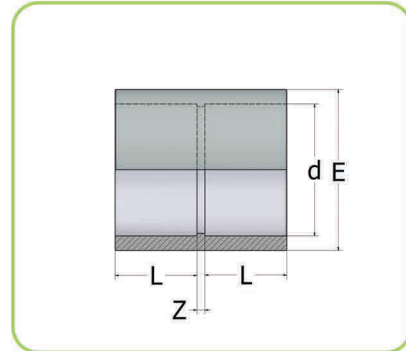

Codes	D	L	Z	E	PN	Quantity	GR
MGSO020Y7	20	16	3	28	16		
MGSO025X7	25	19	3	34	16		
MGSO032W7	32	22	3	42	16		
MGSO040V7	40	26	3	51	16		
MGSO050U7	50	31	3	60	16		81
MGSO063T7	63	38	3	75	16		132
MGSO075S7	75	44	4	88	16	72	222
MGSO090R7	90	51	5	105	16	45	340
MGSO110Q7	110	61	6	126	16	24	540

Elbow °45

MGEY7

كوع 45°

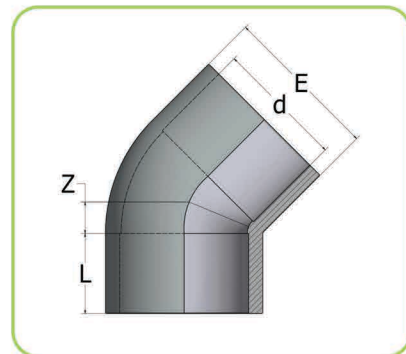

Codes	D	L	Z	E	PN	Quantity	GR
MGEY050U7	50	31	12	60	16	132	95



Tee reducer 90°

MGTR7

مستترك مخفض 90°

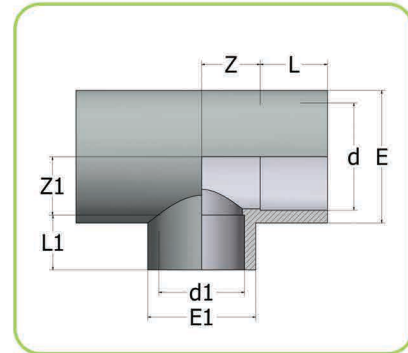

Codes	d×d1	L	L1	Z	Z1	E	E1	PN	Quantity	GR
MGTR090U7	90×50	51	31	47	47	105	61	16	20	700
MGTR090T7	90×63	51	38	47	47	105	75	16	20	712
MGTR090S7	90×75	51	44	47	47	105	89	16	20	735
MGTR110U7	110×50	61	31	57	57	128	61	16	12	1243
MGTR110T7	110×63	61	38	57	57	128	75	16	12	1244
MGTR110S7	110×75	61	44	57	57	128	89	16	10	1288
MGTR110R7	110×90	61	51	57	57	128	105	16	11	960
MGTR125R7	125×90	69	51	66	66	145	105	16	8	1345
MGTR125Q7	125×110	69	61	66	66	145	128	16	8	1500
MGTR160R7	160×90	86	51	82	82	184	105	16	5	2206
MGTR160Q7	160×110	86	61	82	82	184	128	16	4	2345



Strong
product
high-Quality



Conical reducer

MGCR7

مسلوب

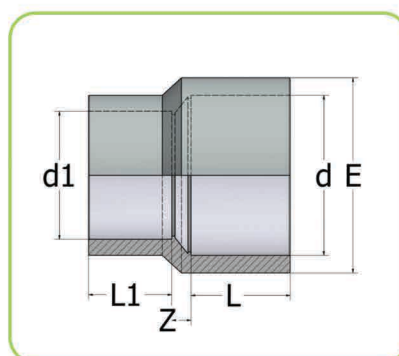

Codes	Exd1xd	Z	L	L1	PN	Quantity	GR
MGCR025Y7	32x25x20	8	22	16	16		
MGCR032Y7	40x32x20	10	26	16	16		
MGCR032X7	40x32x25	10	26	19	16		
MGCR040Y7	50x40x20	13	31	16	16		
MGCR040X7	50x40x25	13	31	19	16		
MGCR040W7	50x40x32	10	31	22	16		
MGCR050X7	63x50x25	20	31	19	16	315	82
MGCR050W7	63x50x32	17	31	22	16	315	90
MGCR050V7	63x50x40	13	31	26	16	315	95
MGCR063W7	75x63x32	23	38	22	16	175	106
MGCR063V7	75x63x40	19	38	26	16	175	145
MGCR063U7	75x63x50	14	38	31	16	175	120
MGCR075V7	90x75x40	25	44	26	16	120	201
MGCR075U7	90x75x50	20	44	31	16	120	205
MGCR075T7	90x75x63	13	44	38	16	120	205
MGCR090U7	110x90x50	30	51	31	16	60	368
MGCR090T7	110x90x63	23	51	38	16	60	379
MGCR090H7	110x90x75	17	51	44	16	60	380
MGCR110U7	125x110x50	39	61	31	16	36	379
MGCR110T7	125x110x63	32	61	38	16	36	378
MGCR110S7	125x110x75	26	61	44	16	36	410
MGCR110R7	125x110x90	19	61	51	16	36	456



Reducing Bush

MGRB7

بوتس مخفض

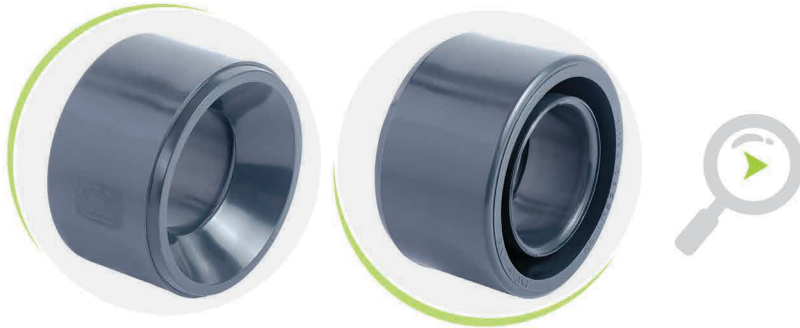

A

B

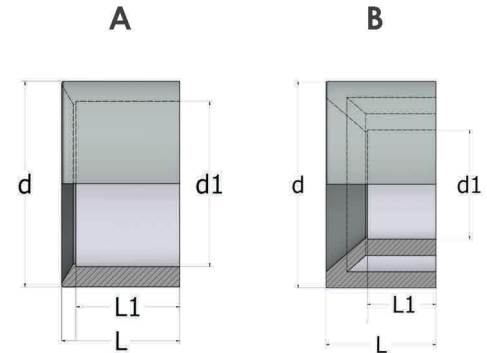

Codes	d x d1	L	L1	Fig	PN	Quantity	GR
MGRB025Y7	25x20	19	16	A	16		4
MGRB032Y7	32x20	22	16	A	16		15
MGRB032X7	32x25	22	19	A	16		10
MGRB040Y7	40x20	26	16	B	16		25
MGRB040X7	40x25	26	19	A	16		28
MGRB040W7	40x32	26	22	A	16		16
MGRB050Y7	50x20	31	16	B	16		
MGRB050X7	50x25	33	19	B	16		45
MGRB050W7	50x32	33	22	B	16		41
MGRB050V7	50x40	33	28	A	16		31
MGRB063X7	63x25	38	19	B	16	350	75
MGRB063W7	63x32	38	22	B	16	350	80
MGRB063V7	63x40	38	26	B	16	350	80
MGRB063U7	63x50	38	31	A	16	350	60
MGRB075W7	75x32	44	22	B	16		110
MGRB075V7	75x40	44	26	B	16		105
MGRB075U7	75x50	44	31	B	16		115
MGRB075T7	75x63	44	38	A	16		77
MGRB090T7	90x63	51	38	B	16	144	180
MGRB090S7	90x75	51	44	A	16	144	130
MGRB110T7	110x63	61	38	B	16	75	360
MGRB110S7	110x75	61	44	B	16	75	270
MGRB110R7	110x90	61	51	A	16	75	270
MGRB125S7	125x75	69	44	B	16	52	355
MGRB125R7	125x90	69	51	B	16	52	416
MGRB125Q7	125x110	69	61	A	16	52	248



Stub Serrated

MGST7

بردة

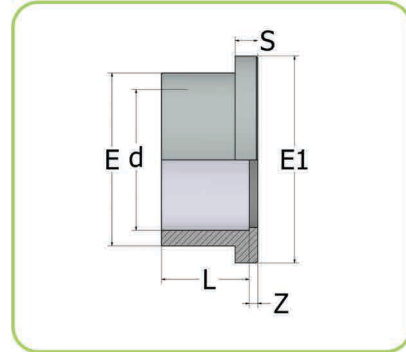

Codes	D	DN	L	Z	S	E	E1	PN	Quantity	GR
MGST063T7	63	50	38	3	9	76	90	16	80	95
MGST075S7	75	65	44	3	10	90	106	16	60	190
MGST090R7	90	80	51	5	11	108	125	16	54	238
MGST110Q7	110	100	61	5	12	128	150	16	40	370
MGST125P7	125	110	69	5	12	145	167	16	20	456
MGST160N7	160	150	86	6	16	183	213	16	16	693

Cap

MGCA7

طبقة

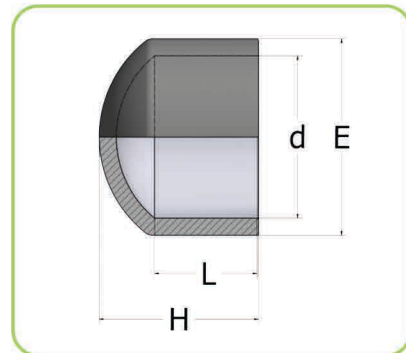
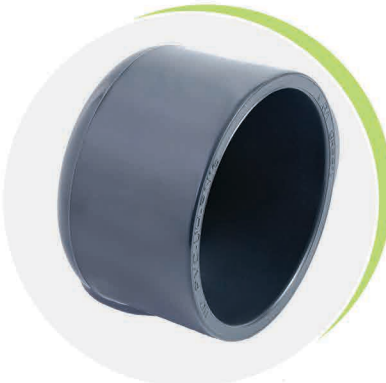

Codes	D	L	H	E	PN	Quantity	GR
MGCA020Y7	20	16	27	28	16		
MGCA025X7	25	19	31	33	16		
MGCA032W7	32	22	36	41	16		
MGCA040V7	40	28	43	52	16		
MGCA050U7	50	32	49	60.5	16		
MGCA063T7	63	39	57	74	16		
MGCA075S7	75	44	67	88	16	120	162
MGCA090R7	90	51	80	104	16	60	290
MGCA110Q7	110	61	95	127	16	40	416



Tee Threaded 90°

MGTT6

مستترك سن 90°

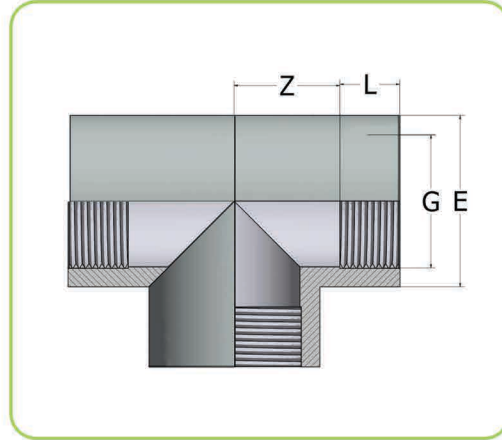

Codes	G	L	Z	E	PN	Quantity	GR
MGTT050U6	1½"	31	26	61	16	65	209
MGTT060T6	2"	36	35	75	16	57	415

Threaded reducer adaptor
BS male / Female threaded

MGTRA6

محول مخفض سن ذكر / انثى سن نظام انجيزي

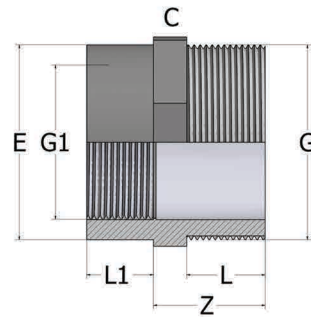

Codes	G x G1	L	L1	Z	C	E	PN	Quantity	GR
MGTRA025Y6	3/4" x 1/2"	16.3	15	26	30	28	16	-	17
MGTRA032Y6	1" x 1/2"	19.1	15	29	36	28	16		18
MGTRA032X6	1" x 3/4"	19.1	16.3	30	36	24	16		26
MGTRA040W6	1¼" x 1"	27	21	39	57	42	16		49
MGTRA040Y6	1¼" x 1/2"	20	16	29	51	29.5	16		52
MGTRA040X6	1¼" x 3/4"	26.9	18.5	29	54	34.5	16		55
MGTRA063Y6	2" x 1/2"								80
MGTRA063X6	2" x 3/4"								85
MGTRA063V6	2" x 1¼"	25.7	21.4	37	65	50	16		97
MGTRA063U6	2" x 1½"	25.7	21.4	37	65	58	16		140



Elbow Threaded 90°

MGELT6

كوع سن

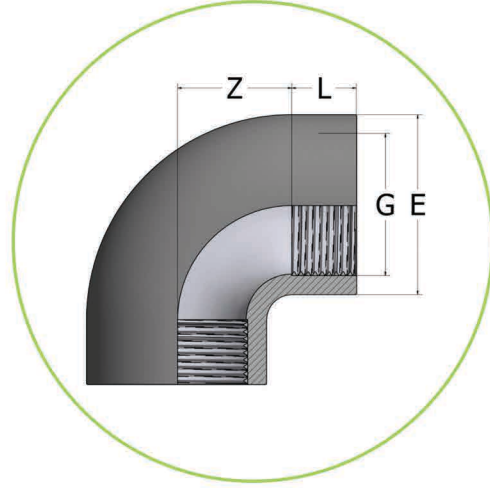

Code	D	L	Z	E	PN	Quantity	GR
MGELT050U6	1½"	31	28	60	16	132	188



Union With -Oring

MGUO4

لاكور تجميع

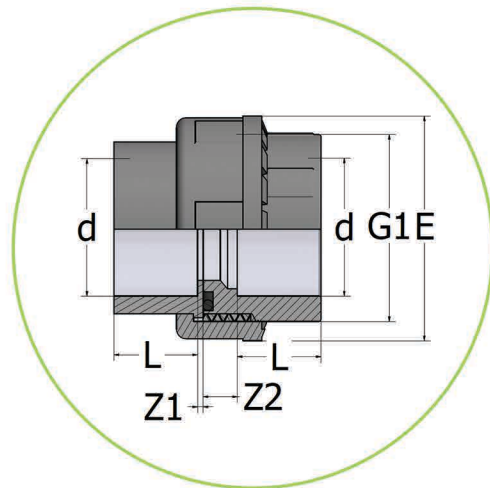

Code	D	L	Z1	Z2	G1	E	O ring	PN	Quantity	GR
MGUO040V4	1¼"	25.5	4	18	53	83	6187	16		-



Loose Flange

MGLF4

فلانسة متحركة

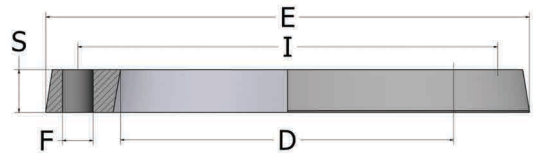

Code	D	DN	E	S	I	F	Drill	Bolts	PN	Quantity	GR
MGLF090R4	3"	90	200	20	160	18	8	M16x90	16	54	341
MGLF110Q4	4"	110	220	22	180	18	8	M16x100	16	40	486
MGLF125P4	5"	125	230	24	190	18	8	M16x100	16	20	557
MGLF160N4	6"	160	285	26	240	22	8	M20x120	16	16	722

Loose Flange

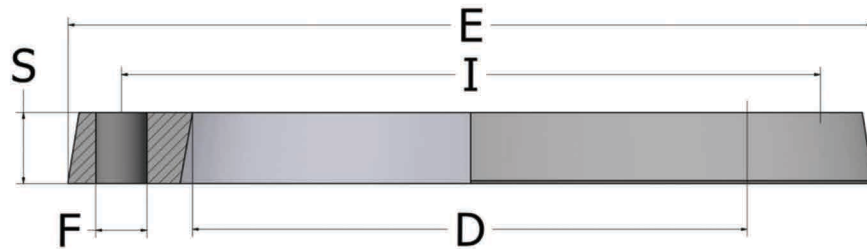

**Adaptor Nipple**

Female solvent socket / BS male threaded

MGAN5

مستترک سن ذو اتجاهین 90°

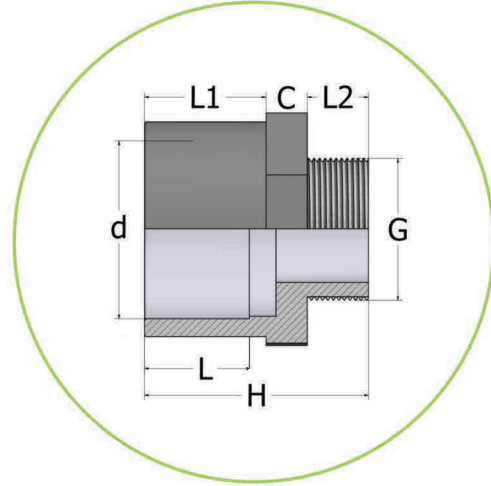

Code	D×G	L2	L1	L	H	C	PN	Quantity	GR
MGAN020X5	20x¾"	16	19	16.3	47	30	16		15.0
MGAN020W5	20x1"								
MGAN025W5	25x1"	19	22	19.1	53	36	16		30
MGAN020U5	20x1½"								
MGAN025U5	25x1½"								
MGAN032U5	32x1½"								
MGAN020T5	20x2"								
MGAN025T5	25x2"								
MGAN032T5	32x2"								
MGAN050T5	50x2"	31	38	25.7	78	65	16		120
MGAN063T5	63x2"	38	44	25.7	84	75	16		150
MGAN075T5	75x2"								





Tee Two sided Threaded 90°

MGTST5

مستترك سن ذو اتجاهين 90°

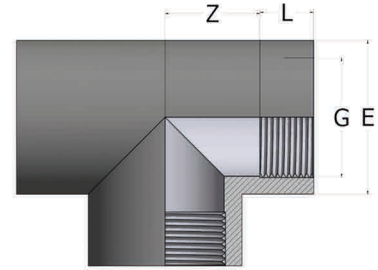
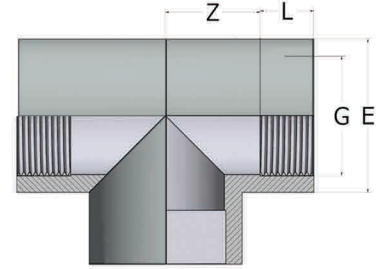

Code	D×G	L	Z	E	PN	Quantity	GR
MGTST050U5	50-1½"	21.4	37.6	61	16	65	209
MGTST063T5	63-2"	25.7	46.3	75	16	57	415

Tee Central Threaded 90°

MGCT5

مستترك سن وسط 90°

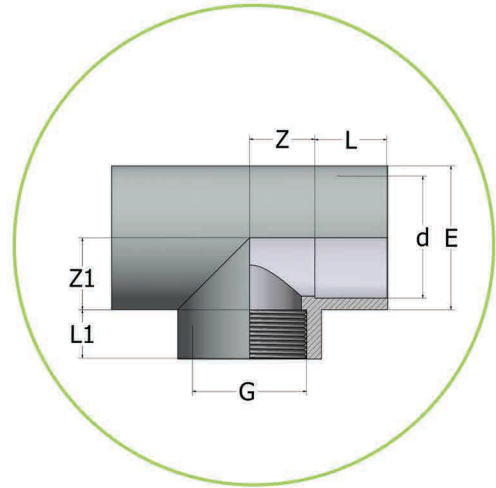

Code	D×G	L	Z	E	PN	Quantity	GR
MGCT050U5	50-1½"	21.4	37.6	61	16	65	209
MGCT063T5	63-2"	25.7	46.3	75	16	57	415



Elbow Plain/ Threaded 90°

MGEPT5

كوع سن/ لصق 90°

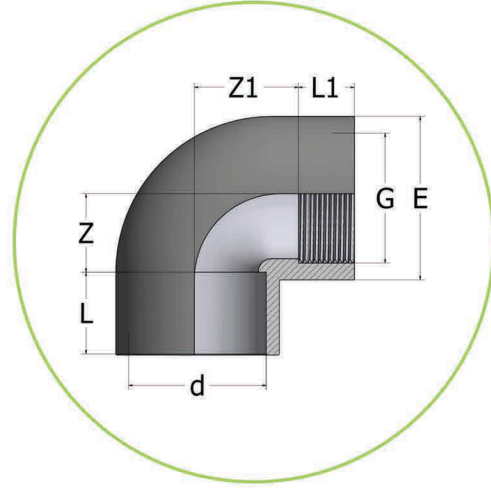

Code	D	L	Z	E	PN	Quantity	GR
MGEPT050U5	50-1½"	31	28	60	16	132	188

Tee Double Reducer

MGTD5

مستترك مخفض مزدوج

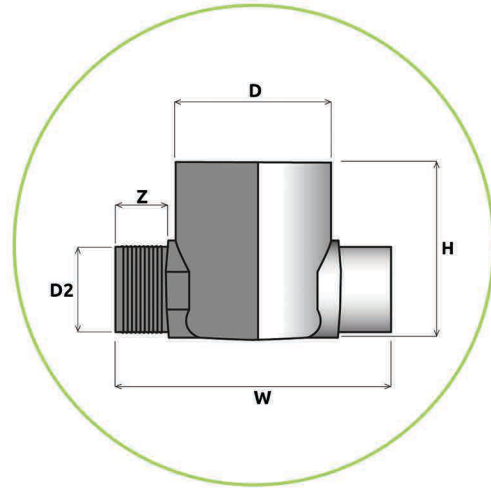

Code	Dxd2	H	W	Z	Quantity	GR
MGTD5090T5	90X2"	105	185	30		



Box Valve

MGBV6

غرفة محابس

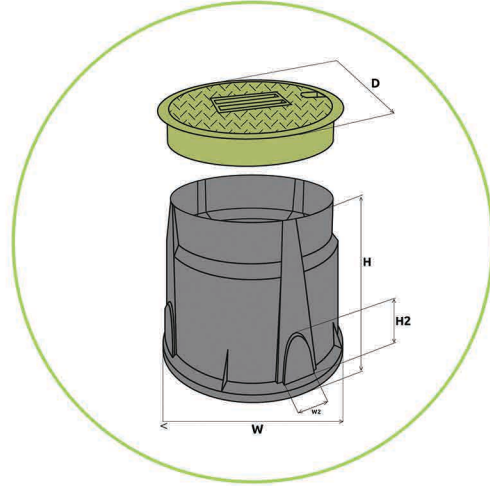

Code	d	D	W	H	H2	W2	Quantity	GR
MGBV225K6	10"	275	350	250	65	55	1	1900
MGBV160N6	6"							525



Strong
product
high-Quality



Miga green

plastic industries

www.migagreen.com



Ask for more products ...

High Quality
Egyptian
Industry



the Size of Box



Length	Width	High
55.5cm	35.5cm	32cm



CERTIFICATES

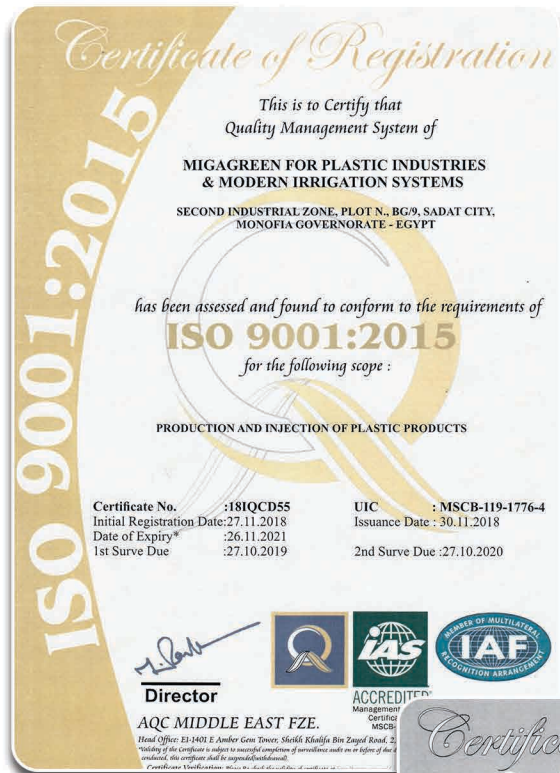

الهيئة القومية
لمياه الشرب والصرف الصحي
إدارة الاختبارات والرقابة على الصناعة

National Organization
For Potable Water & Sanitary Drainage
Administration of Testing & Industry Supervision

شهادة اعتماد منشأة إنتاجية
(مواسير بلاستيك UPVC)

اسم المنشأة : شركة ميجا جرين للصناعات البلاستيكية وانظمة الري الحديث
عنوان الإدارة : ١٥ شارع نابلس- المهندسين- القاهرة
عنوان المصنع : المنطقة الصناعية الثانية قطعة ب ج/٩ - السدات- منوفية
السجل التجاري: ١٨٦٦٤ مكتب سجل تجاري : منوف محافظة : منوفية
بإحض رقم تسجيل ضريبي : ٦٤٠-٩١٩-٥٤ مأمورية: المهندسين محافظة: الجيزة
سجل صناعي رقم: ١٩٨٩/١٥٦٩٤ سنة الإصدار: ٢٠١٨ نوعية الصناعة: كيميائية
رخصة: (موقتة) ملف رقم: ٢٢٢٠ (مدينة) المنوفية

أهم المنتجات المعتمدة لدى الهيئة :-

١- القطع الخاصة البلاستيك UPVC حتى قطر ١٦٠م بضغوط مختلفة للاستخدام في مياه الشرب والصرف الصحي (منتج بطريقتي الحقن)

- طبقا للمواصفات القياسية المصرية و العالمية و القرار الوزاري رقم ٢٧٧ لسنة ٢٠٠٠ وتعديلاته
- يتم الالتزام بتعليمات الإدارة و الموضحة خلفه وفي حاله مخالفتها يعتبر لاغى
- شهادة الاعتماد لا يعمل بها كبديل عن شهادات الاختبار التي تصدر لكل امر توريد على حده

المشرف العام
مهندس
"سيد ربيع السيد"

صالح في ٢١٩/٤/١٧
ساري حتى ٣/٤/٢٠١٩

shereen

١٥٠٠-٢٠١٤ اس ١٣٢٨٤ الاميرية



Miga green
plastic industries

High-Quality
products

منتجات
عالية الجودة



Miga green
plastic industries

High-Quality
products

منتجات
عالية الجودة